

**WARNING!!!**

**WE INFORM THAT THE OFFERED CONTROL UNIT CAN BE ONLY APPLIED TO THE FITTING DEVICES. THE REQUIREMENTS OF THE TECHNICAL AND BUILDING STANDARDS CONCERNING THE CORRECTNESS OF STOVE AND HEATING SYSTEMS HANDLING THE FIREPLACE INPUTS MUST BE MET.**

**WRONG USAGE OF THE CONTROL UNIT CAN LEAD BOTH TO ITS DAMAGE AND IN EXTREME CASES TO THE DAMAGE OF THE FIREPLACE INPUT AND HEATING SYSTEM CONTROLLED BY THE FIREPLACE AS WELL, ALONG WITH THE DEVICES THAT COOPERATE WITH THE HEATING SYSTEM.**

**WARNING!!!**

**We inform that in case of systems based on the water cap you should pay attention to the location of mounting the temperature sensor of water in the cap. Because of high temperature maintaining close to the water cap and coming from that both a risk of damaging the sensor and false measurements of temperature, its assembly should be carried out on the pipe channelling water from the water cap beyond the fireplace.**



**Zakład elektroniczny TATAREK Jerzy Tatarek**

50-559 Wrocław, 75 Swieradowska st.  
ph. (071) 367-21-67, 373-14-88, fax 373-14-58; Tax index number 899-020-21-48;  
Bank account: BZ WBK S.A. WROCLAW 6910901522-0000-0000-5201-9335  
www.tatarek.com.pl.; E-mail: [tatarek@tatarek.com.pl](mailto:tatarek@tatarek.com.pl)



**Zakład elektroniczny TATAREK Jerzy Tatarek**

**RT08GOS2/2015/v.3.0/ANG**

***USER MANUAL***

*v.3.0 (19.01.2015 program version from 3.0)*

**FIREPLACE OS2 (RT-08G-OS2)**

**COMBUSTION OPTIMIZER  
FOR THE FIREPLACE WITH  
ACCUMULATION MASS**

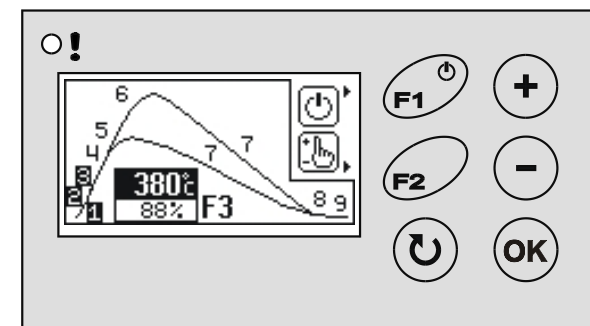

**1. Basic technical parameters**

Power	230V/50Hz
Auxiliary power	Rechargeable battery 4,8V/60mAh
Power consumption without load	5W
Maximum connection power	250W
Operation conditions	0-40 °C, humidity 10-90% (no condensation)
Housing protection class	IP41
Fuse	6,3A/250V
Number of outputs to control the flap drive or draught generator	1 * 250W/230V/50Hz
Number of nonvoltage control outputs	1 * switching contacts
Number of outputs to control the air damper drive	1 * 5V/500mA/DC
Number of temperature sensors	2 * Thermocouple type K (0..+1300°C)
Temp. measurement precision	5°C
Temp. measurement resolution	1°C



## CE CONFORMITY DECLARATION

Ref. No. 58.RT.01.2007/1/B

We, **ZAKŁAD ELEKTRONICZNY TATAREK Jerzy Tatarek**  
75 Swieradowska St. , 50-559 Wrocław

declare under our sole responsibility that  
the product: **Combustion Optimizer**

model: **RT-08G-OS**

is in conformity with the basic requirements included in Directive EMC 2004/108/WE of 15.12.2004 (the electromagnetic compatibility law of 13.04.07) and Directive LVD 2006/95/WE of 21.08.07 (Laws Journal of 2007 No. 155 pos. 1098) regarding the requirements for electric devices.

To the conformity evaluation the following harmonized standards were used:

PN-EN 60730-2-1: 2002 - Automatic electric regulators for house usage and the like. Part 2-1: Specific requirements regarding electric regulators for electric house devices

PN-EN 60730-1: 2002 - Automatic electric regulators for house usage and the like. Part 1: General requirements.

PN-EN 55022: 2000 - Electromagnetic compatibility (EMC)- IT devices Characteristics of radioelectric noises. Acceptable levels and measurement methods

Complementary information:

Laboratory IASE 51-618 Wrocław, 1 Wystawowa st.

Test report No. 39/DL/I/07 of 22.06.2007  
41/DL/I/07 of 03.07.2007

Electronic Engineering Plant TATAREK  
has initiated management system and complies with the following standard :  
ISO9001: 2000 CERTIFICATE No. 133/2004 of 01.2004  
Polish Foreign Trade Chamber

The last two digits of the year in which the CE marking was affixed: 07

Place of issue:

Wrocław

Date of issue:

08.2007

Manufacturer representative:

Mirosław Załępa

Position:

Designer

## 2.1 Operation phases of the control unit

1. **F0/Fstop** - Standby phase. The control unit awaits opening the door and preparing the fuel for the next heating. In the F0 state the air damper is closed.
2. **F?** - Temporary state. After switching on the power the control unit waits for stabilization of conditions and decides if it should pass to the F0 phase (the furnace is burnt out) or the F1 phase (start if the furnace is fired up). In the F? state the air damper is open.
3. **Fx** - State after opening the furnace door. The air damper is fully open.
4. **F1** - Start phase. After loading the fuel and its lighting you close the furnace door. It's a signal for the control unit that the combustion cycle has begun. The air damper is fully open.
5. **F2** - Heating-up phase. After reaching the limit temperature the pass to the phase F3 follows.
6. **F3,4,5** - Phases of temperature increase. The air damper is set depending on the temperature according to the combustion curve
7. **F6** - Burning phase. Awaiting the maximum combustion temperature of the process
8. **F7** - Phase of decreasing temperature. The air damper is gradually closed
9. **F8** - Embers phase. Signalling the demand for replenishing the fuel
8. **F9** - Phase of removing the exhaust gases. The air damper first opens up and then closes and there's the pass to the standby phase.

! The control unit can control the fireplace without the opening sensor of the door. In that case the keyboard buttons are used.

## 2.2 Temperature sensors

Temperature sensors are thermocouples type K, which can measure the range 0 °C ..1300 °C . The sensor should be mounted over the exhaust gas output from the furnace. The sensor T2 (optional equipment) monitors the temperature on the output of the heat accumulation module (MAC).

## 2.3 Limiting the maximum temperature of combustion

For the fireplace inputs whose construction requires limiting the maximum temperature of combustion it's possible to program the limit. Exceeding the temperature defined by the parameter "<20> Fireplace T.MAX" causes that the air damper closes to the level of 30% (parameter "<21> ChokeV State T.MAX") and the alarm turns on. The process of shutting the air damper begins at 50 °C before reaching that limit. Turning off the alarm and the return of normal operation of the air damper follows if the temperature decreases again. The default 1300 °C practically indicates that there's no limit (it's the maximum temperature of operation of the temperature sensor).

## 2.4 Air damper

The air damper is mounted on the input of cold air to the combustion chamber. The position of the air damper is calculated by the control unit depending on the combustion process. The change of the position is carried out by the drive of the air damper in 20sec cycles

! In the turn-off state (also the decline of the power) the combustion process is not controlled. In order to prevent CO concentration increase( in case of the partial combustion before reaching the embers phase ) the air damper is opened.

## 2.5 Increasing the chimney draught

During normal operation the heated exhaust gases cool off flowing through the MAC (Heat Accumulation Module). During the heating-up phase, when the fireplace is cold, its draught can be insufficient..The control unit can control the system of increasing the chimney draught with the K1 output. To this output you can connect a actuator of the by-pass flap MAC or draught generator. Depending on the applied actuator and the paramater "<50> K1 MODE" we've got the following possibilities:

**Version 1:**

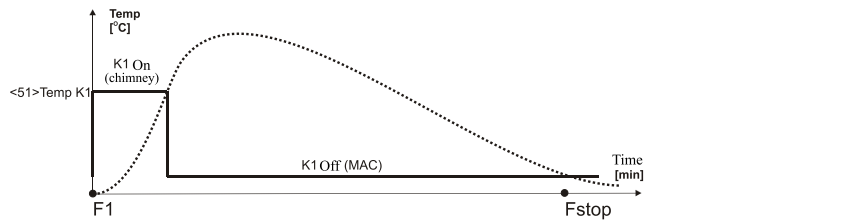

The parameter "<50> K1 MODE"=1. In the standby state the output K1 is switched off. The flap is directed towards the MAC. The start of the combustion causes turning on the output K1 and directing the combustion gas directly to the chimney. After reaching the preset temperature ("<51> Temp. Flap K1") the flap is switched off and it directs the gas to the MAC.

**Version 2:**

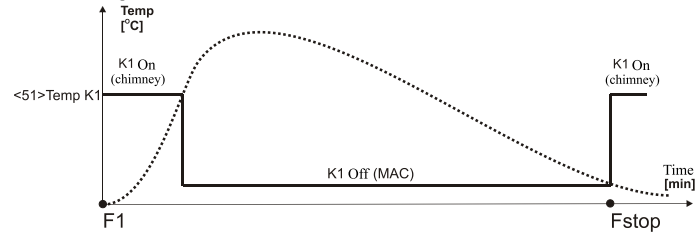

The parameter "<50> K1 MODE"=2. In the standby state the output K1 is switched on. The flap is directed towards the chimney. After reaching the preset temperature ("<51> Temp. Flap K1") the flap is switched off and it directs the gas to the MAC. After the combustion the K1 output is switched on. The flap is again directed to the chimney.

**Version 3:**

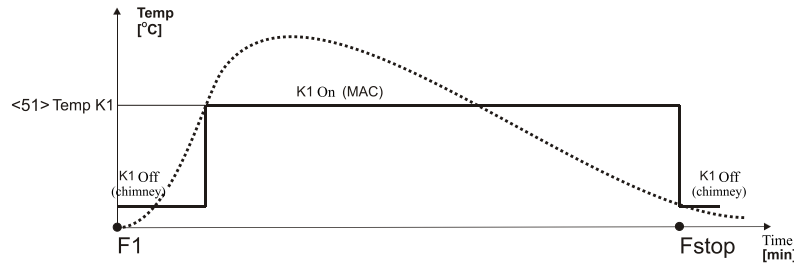

The parameter "<50> K1 MODE"=3. In the standby state the output K1 is switched off. The flap is directed towards the chimney. After reaching the preset temperature ("<51> Temp. Flap K1") the control unit switches on the K1 output causing redirecting the combustion gas to the MAC. After the combustion the K1 output is switched off. The flap is again directed to the chimney.

**Version 4:**

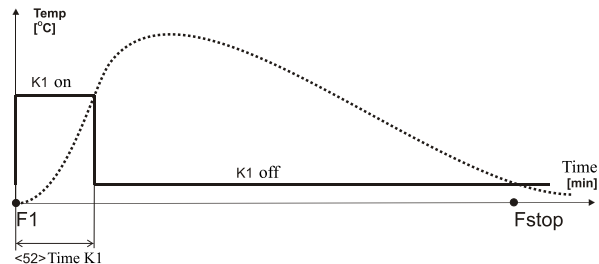

The parameter "<50> K1 MODE"=4. The fan of the draught generator is connected to the output K1. The generator switches on after opening the fireplace door (the sensor of opening the door is needed) and switches off after 1min (The parameter "<52> Rundown Time of K1") since closing the door.

**WARRANTY**

1. Warranty is valid [24] months from the date of sale.
2. Producer does not take responsibility for any mechanical damages made by user.
3. MAKING REPAIRS OR MODIFYING THE RT-08G-OS CONTROL UNIT BY USER IS FORBIDDEN AND CAUSES WARRANTY CANCELATION
4. Warranty card is valid only with date of sale, seller's signature and stamp
5. Warranty and after-warranty repairs should be done only by producer, damaged control units should be sent to producer in order to make all repairs needed.
6. Warranty protection involves the EU
7. Warranty does not exclude, not restrict and not suspend buyer's rights coming from the incompatibility of the article with the agreement (Laws Journal No. 141 Pos. 1176)

**WARNING !**

**ANY MODIFICATION OF THE CONTROL UNIT MADE BY USER CAN BE THE CAUSE OF SAFETY CONDITIONS DETERIORATION AND CAN EXPOSE THE USER TO ELECTRIC SHOCK OR DAMAGE DEVICES SUPPLIED.**

Connection cable of control unit may be replaced only by producer or his authorized service locations

**WARNING!**

1. Producer does not take the responsibility for damage caused by atmospheric discharge
2. and overvoltage in the mains
3. Burnt fuses are not subject to warranty replacement

Date of sale

Seller's signature and stamp

Register No. GIOS: E 0002240WZ	ARGO-FILM Recycling Plant No. 6
Worn out electronic and electric devices must be transferred to the utilization collection place, where will be accepted for free	180 Krakowska st., 52-015 Wrocław ph.: 071 794 43 01, 0 515 122 142



**Zakład elektroniczny TATAREK Jerzy Tatarek**

50-559 Wrocław, 75 Swieradowska st  
 ph. (071) 367-21-67, 373-14-88, fax 373-14-58; tax index number 899-020-21-48;  
 Bank account : BZ WBK S.A. O/WROCLAW 6910901522-0000-0000-5201-9335  
 www.tatarek.com.pl; E-mail: tatarek@tatarek.com.pl



## 4 Installing the control unit

- ! THE CONTROL UNIT IS SUPPLIED BY 230V/50HZ . ANY MOVES REGARDING INSTALLATION SHOULD BE MADE AT THE DISCONNECTED MAINS.
- ! THE CONTROL UNIT HAS TO BE CONNECTED TO THE MAINS WITH THE ZERO-PIN.
- ! THE CONTROL UNIT SHOULD NOT BE EXPOSED TO WATER AFFECTING. ITS ENVIRONS OUGHT TO BE CLEAN.
- ! THE PRODUCER DOESN'T TAKE ANY RESPONSIBILITY FOR DAMAGES CAUSED BY WRONG USAGE OF THE CONTROL UNIT.

Wiring according to fig. 3

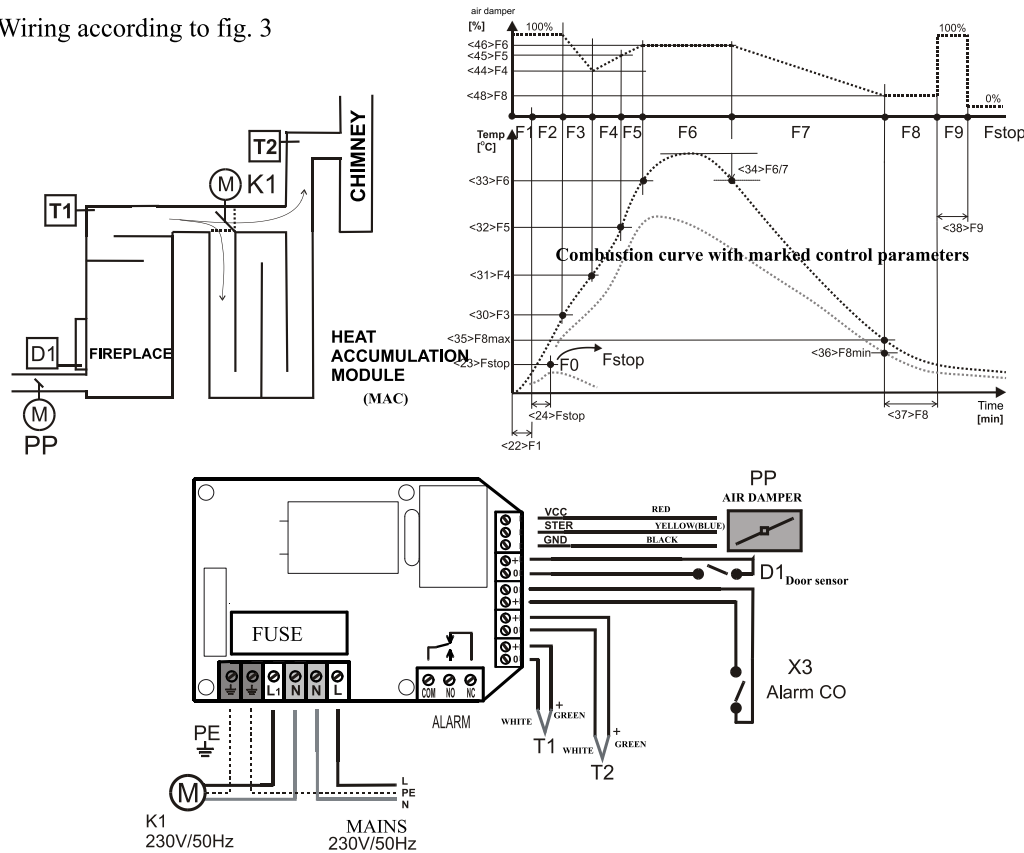
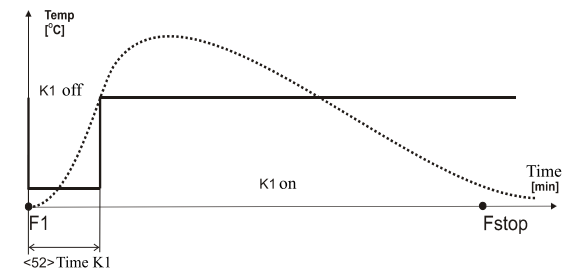

Fig.3 Wiring scheme

- PP- Electronically controlled air damper TATAREK
- X3- Input to connect a control device of CO concentration. The input "+" has higher potential (it's important for Open Collector Systems). Short-circuit of the contacts means the exceeding of permitted CO concentration. At the lack of CO control you leave the contacts not connected.
- D1- Sensor of opening the furnace door. The type of sensor is determined by the parameter "<12> Type of Door Sensor"
  - in case of short-circuit sensor (at the closed door the terminal D1 is short-circuited), set <12>=2.
  - in case of open out sensor (at the closed door the terminal D1 is open), set <12>=1 or short the terminal D1 and set <12>=2.
- T1- Sensor of combustion temperature. Thermocouple type K (the wire of higher potential is green, of lower one is white)
- T2- Additional temperature sensor. Thermocouple type K (the wire of higher potential is green, of lower one is white)
- K1- Flap drive of the by-pass of the heat accumulation module or draught generator (option)

## Version 5:



The parameter "<50> K1 MODE"=5. The ventilation is connected to the K1 output. The ventilation switches off after opening the door (a door sensor is required) and switches on after 1 min (Parameter "<52> Run-down Time of K1") from the time when the door is closed..

## 2.6 Additional functions of the control unit

- ! An external device controlling CO concentration can be connected to the control unit. In case of detecting the danger the air damper opens up improving the ventilation of room, additionally the signal alarm switches on.
- ! The control unit switches on the ALARM output in case of damage of the temperature sensor of the furnace (T1) or exceeding of CO concentration.

## 3 Operating the control unit

There are elements on the control panel (fig. 2).

! In the turn-off state only the orange standby state LED (7) lights and the graphic display shows current temperature of the fireplace. The air damper is open and the outputs switched off.

! The turn-on of the control unit follows by pressing the button ON/OFF/F1 (3). **If any alarm condition occurs (failure of temperature sensor, exceeding of the maximum temp. of the stove, CO danger) the control unit also turns on.** In order to turn it off press once more the button (3) and at the same time hold it down for about 1sec. At the turned-on control unit the F1 button can have additional meaning, if there's an icon showing up at it.

! In case of supply voltage decline the control unit comes back to the state before the decline. The operation state is presented on the graphic display (2). The screens inform about the operation of devices, temperature of sensors; they make it possible to change the parameters etc.. The change of screen is done by pressing the CHOOSE button (7). If this is the screen that is able to change a parameter, press the CONFIRM button (6), which causes blinking of the parameter field to be changed. By pressing "+" (4) or "-" (5) one can alter its value. By clicking the CONFIRM button (6) one confirms the changes - the parameter field stops blinking.

! **The changed parameter not confirmed for 30 secs is not accepted by the control unit and it recalls a previous value of the parameter.**

! The button F2-ESC (8) causes cancelling the current operation and going over to the screen of control unit operation (the F2 button can have additional meaning, if there's an icon showing up at it).

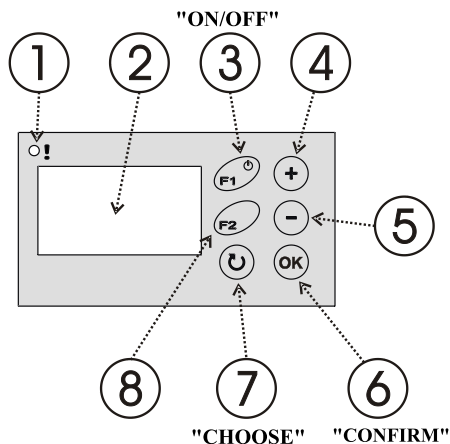

Fig.2 View of control panel

1. Status LED diode of the control unit:
  - o emergency/alarm - red
  - o standby - orange
  - o operation - green
  - o manual operation MANUAL - the green diode blinks.
2. Graphic display
3. Button F1/ON-OFF
4. Button to increase a value
5. Button to lower a value
6. Button to confirm changes
7. Button to choose a parameter
8. Button F2/ESC

### 3.1 Alarm screen

Alarm screen is not seen till the following emergency situation takes place:

1. Damage of the sensor T1 . The text "Fplace temp. sensor (T1) damaged" shows up.
2. Damage of the internal sensor of the reference temperature. The text "Temp. error (T0)" shows up.
3. Exceeding of the limit concentration of CO by short-circuiting the contacts X1. The text "GAS !!" shows up.
4. Exceeding of the maximum temperature of the fireplace. The text "Too high temp. of the fireplace" shows up.

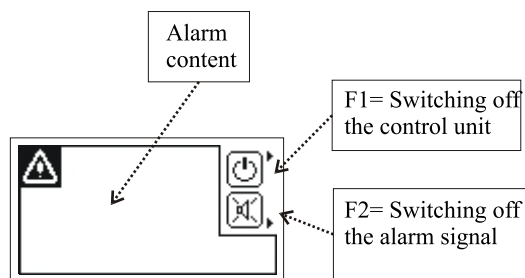

PARAMETERS LEVEL 4				
PARAMETERS CAN BE CHANGED ONLY AT UNLOCKED PASSWORD				
No	NAME	RANGE	DEFAULT	FUNCTION
90	ProdNo.	0....n	1	Number of the parameters set - dependent on fireplace producer
91	RESET	OFF/ON	OFF	Setting the value of "ON" causes the recall of all parameters to their default pre-sets and restarts the control unit
92	PASSWORD	0...9999	0000	„0000“ PASSWORD OFF „-----“ PASSWORD ON
99	Service Screen	OFF/ ON	OFF	The ON value causes diagnostics screen to be added for servicing.

! Parameter number only plays an auxiliary role. It's used to unambiguous identification of the parameter name e.g. for different language versions.

#### Password

The changes of important parameters are possible only at unlocked password. To unlock the password you need to input proper sequence of digits with the buttons "+/-". With the CHOOSE button (7) to change the digits position and CONFIRM button (6) to acknowledge all and finish the procedure of changing the password. The unlocked password is set to "0000". Once again entering into the password change procedure causes a new password to be set.

! PASSWORD „9999“ HAS CONSIDERABLE MEANING. IT CAUSES THE REACTIVATION OF THE PREVIOUS PASSWORD IF PRESENT WITHOUT IT BEING EXPOSED.

! PASSWORD OF PRODUCER'S SERVICE IS UNIQUE AND IS NOT DEPENDENT ON THE USER'S PASSWORD- IT SHOUDN'T BE EXPOSED TO THE USER. INSTEAD OF THAT THE SERVICE CAN SET TO THE USER HIS OWN PASSWORD.

#### Examples of passwords:

1. The control unit is installed with the unlocked password. The user can enter his own password e.g. "1234". From this moment the important parameters cannot be altered without the password being unlocked (that is, resetting the password "1234"). After changing essential parameters the user can leave the control unit unlocked, set any new password or enter "9999", which activates the password "1234"
2. Producer gives the control unit with the set password. The user cannot alter the important parameters. The servic can change the settings with its own secret password. At the end a serviceman enter the secret password or "9999", the user still hasn't access to the important parameters.
3. Producer gives the control unit with the set password. The user cannot alter the important parameters. The servic can change the settings with its own secret password. At the end a serviceman leaves the control unit unlocked, the user now has access to the important parameters. He can enter his own password like in example No. 1.
4. Producer gives the control unit with the set password. The user cannot alter the important parameters. The servic can change the settings with its own secret password. At the end a serviceman sets the password e.g. "1234" and tells it to the user, the user has access to the important parameters but without knowing the password the other persons cannot make the changes.
5. The user has the unlocked control unit or his own password. Serviceman decides, the user though oughtn't have access to the important parameters. The serviceman locks the control unit with his secret password, which removes the user's password and locks the control unit.
6. Serviceman doesn't have to know the user's password. Always he can use his own secret password and at the end lock with the "9999", which reactivates the user's password.

#### Demonstration change of the "<30> Temp. F3" parameter (Parameters level 2)

Press:

- \*repeatedly button "CHOOSE"(7) till the "Parameters level 0" parameter setting screen appears.
- \*„CONFIRM" button -> „0" starts blinking
- \*twofold button "+" -> „2" blinks
- \*„CONFIRM" button -> „2" stops blinking (Parameters level 2 was chosen)
- \*repeatedly „CHOOSE" button -> „<30> Temp. F3" shows up(actual value)
- \*„CONFIRM"button -> actual value to be changed begins blinking
- \*„+/-" -> setting a new value
- \*„CONFIRM" -> confirming the new value
- \*repeatedly "CHOOSE" button till the „\*\*\*" parameter end setting screen appears.
- \*once more "CHOOSE" --> Return to the operation screen of the control unit

PARAMETERS LEVEL 2					
PARAMETERS CAN BE CHANGED ONLY AT UNLOCKED PASSWORD					
No	NAME	RANGE	DEFAULT		FUNCTION
20	Fireplace T.MAX	400..1300°C	800 °C		Maximum temperature of the fireplace. After exceeding it the alarm turns on and the air damper closes to the value defined by the next parameter <21>. The default 1300°C indicates the function is not active.
21	ChokeV state T.MAX	10...50 %	30 %		Air damper opening when the temperature exceeds "T.max"
22	Time of F1 (t.F1)	15...600s	60s		Delay of control start (time span of the phase F1)
23	Temp. RESTART (T.F?)	10...1250°C	45 °C		Restart temperature after switching on the power. If after switching on the control unit the temperature in the furnace is higher than "Temp. RESTART" then an automatic restart follows.
24	Time STOP (t.F?)	0...600s	500s		After this time the transition to the standby state (STOP) follows if the temperature "Temp. RESTART" is not reached.
30	Temp.F3	30...1250°C	200 °C		Temperature of starting the phase F3
31	Temp.F4	50...1250°C	410 °C		Temperature of starting the phase F4
32	Temp.F5	50...1250°C	600 °C		Temperature of starting the phase F5
33	Temp.F6	50...1250°C	700 °C		Temperature of starting the phase F6
34	dTemp.F6/7	-10...-300°C	-100 °C		Temperature drop in relation to the maximum one in F6 indicating the start of the phase F7
35	Temp. F8max	50...1250°C	460 °C		Temperature of starting the phase F8 (embers phase)
36	Temp. F8min	50...1250°C	320 °C		Temperature of starting the phase F8 (embers phase) in case the maximum temperature was reached in F3,F4 or F5 (no phase F6)
37	Time of F8 (t.F8)	1...720 min	20 min		Time span of the phase F8
38	Time of F9 (t.F9)	0...10 min	1 min		Time span of the phase F9. Scavenge time. Opening the air damper and burning down the exhaust gases
44	CVS . F4	0...100 %	60 %		air damper opening at the start of the phase F4
45	CVS . F5	0...100 %	75 %		air damper opening at the start of the phase F5
46	CVS . F6	0...100 %	90 %		air damper opening at the start of the phase F6
48	CVS . F8	0...100 %	10 %		air damper opening at the start of the phase F8

#### CVS= ChokeV State F\*

PARAMETERS LEVEL 3					
PARAMETERS CAN BE CHANGED ONLY AT UNLOCKED PASSWORD					
No	NAME	RANGE	DEFAULT		FUNCTION
50	K1 MODE	1...4	1		System type of increasing the chimney draught K1 (see ch. 2.5)
				1..3	Flap MAC
				4	Draught generator
51	Temp. Flap K1	200..1000°C	700 °C		Combustion temperature causing the switch-over of the by-pass flap. Switch-on of the MAC block (at the option <50>=1...3 (see ch. 2.5)
52	Rundown Time of K1	0...20 min	1 min		Time span of operation of the draught generator after shutting the furnace door (at the option <50>=4) see ch.2.5
16	Control - Relay	1...1	1		Switching on the relay CONROL if 1  alarm situation occurs
12	Type of door sensor	1...2	1	1	Open-out sensor ( at the closed door the terminal D1 is open) or there's no door sensor
				2	short-circuit sensor ( at the closed door the terminal D1 is shorted)

! Alarm situation is accompanied by a broken sound alarm that can be turned off by pressing the button F2

The CHOOSE button (7) causes the next screens to be called up.

### 3.2 Screen of the automatic operation of the fireplace

The screen enables the control of the control unit operation. A theoretical combustion curve is presented on the display in 2 versions- the first concerning the full combustion and the second one concerning the partial combustion, that is, when the drop of temperature before the phase F6 occurred during the combustion process. The blackened phase numbers indicate the history of combustion process.

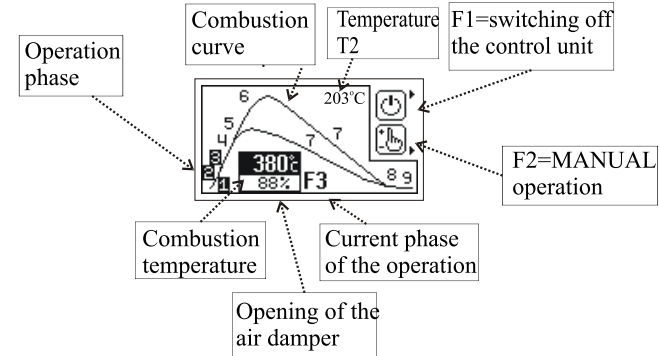

! In the automatic mode each opening of the door causes the air damper to be set at 100% and each shutting of the door causes the combustion process started and the diode (1) lights. If the furnace is cold then after the time "<22>+<24>" (see the parameters) the control unit closes the air damper and passes to the standby state.

Likewise the control unit acts when the power turns on.

! During the operation without the sensor of the door the panel buttons are used for controlling. Pressing "+" (4) causes opening the air damper and starting the cycle. Before each opening the door the air damper should also be opened by pressing "+" (4) in order to avoid the smoking. After lighting the fuel and closing the door you must again press "+" (4) to restart the combustion process.

! Reaching the embers phase F8 is accompanied by a broken sound signal (switch-off with the button CONFIRM(6) ), blinking number of the phase with the flame symbol and blinking of the green diode (8), which indicates the need for replenishing the fuel in case of continuing the heating.

The control unit can run in the automatic or manual mode. The longer pressing F2 (8) about 2secs causes the pass to the manual mode.

The CHOOSE button (7) causes the next screens to be called up.

### 3.3 Screen of the MANUAL operation of the fireplace

The transition to the MANUAL mode -(the status LED diode (1) blinks)-enables taking control of the combustion process. The air damper opens up 100%. From this moment you can manually control the air damper: the button "-" (5) causes shutting (1 step/10%) and the button "+" (4) causes its opening. With the button "F2" (8) you can cyclically change the controlled circuit to: switching on the circuit that increases the chimney draught, relay CONTROL/ALARM and once more the air damper. The selected circuit blinks on the display. Same like for the air damper with the button "+" (4) you switches on and with the button "-" (5) you switches off the selected circuit.

! In the MANual mode you must not fully close the air damper before reaching the embers phase, because there's real danger of increasing CO concentration !!

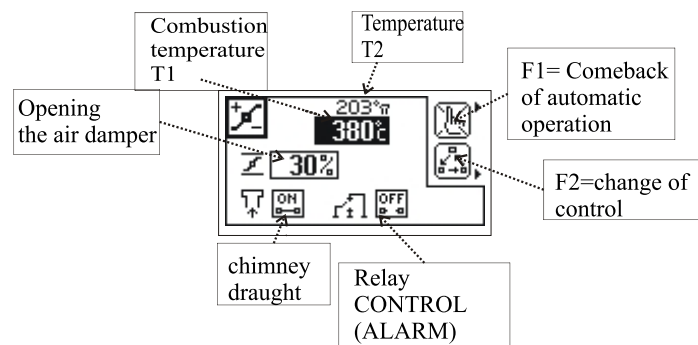

The comeback of the automatic mode is initiated by pressing the button "F1" (3).

By pressing the button CHOOSE (7) you go over the next screens..

### 3.4 Screen of combustion history

This screen shows the history of combustion. The screen isn't visible if the fireplace operates in the manual mode "MANUAL". The start of registration follows with the start of the phase F1 and the end of registration after F9. The temperature is registered every 50secs. The start of registration begins from the temperature 0°C, which constitutes the marker of the new cycle of combustion (see the fig. below)

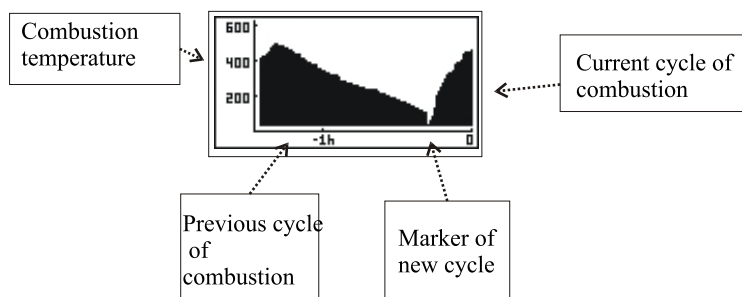

By pressing the button CHOOSE (7) you go over the next screens..

### 3.5 Information screen

This display informs about the state of the circuits connected to the control unit.

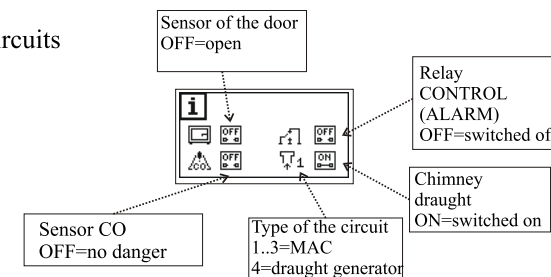

By pressing the button CHOOSE (7) you go over the next screens..

### 3.5 Screen of setting the parameters

The first screen shows "Parameters level 0", which means the parameters aren't available. After changing the level to "1", "2", "3" or "4" the successive screens show the values of parameters.

The last screen contains "\*\*\*\*" after which it comes back to the above mentioned screens.

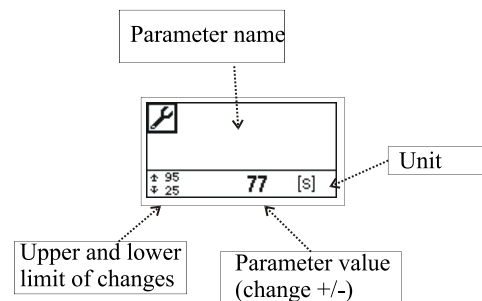

! PARAMETERS ADAPT THE CONTROL UNIT TO THE PROPERTIES OF THE FIREPLACE. THEIR CHANGE SHOULD BE CONSULTED WITH THE PRODUCER OF THE FIREPLACE. INCAUTIOUS CHANGES CAN CAUSE UNSTABLE AND INEFFICIENT OPERATION OF THE SYSTEM.

PARAMETERS LEVEL 1						
NR	NAME	RANGE	DEFAULT	SETTING	FUNCTION	
10	Signal	OFF/ON/ ON+ ALARM	ON+ ALARM		OFF	The click of buttons is off Sound alarm is off
					ON	The click of buttons is on Sound alarm is off
					ON+ ALARM	The click of buttons is on Sound alarm is on
					OFF+ ALARM	The click of buttons is off Sound alarm is on
11	Language	polski/ english/ deutsch	polski		Language version	
13	LCD backlight	OFF/ ON	OFF		OFF - Backlight of the display is active for 2min since last pressing the button ON - Backlight is active constantly if the control unit is switched on. Switching off the backlight indicates it assumes the value of the next parameter <14>	
14	MIN LCD backlight	0...25%	10%		Minimal value of the backlight (it's important for the negative display) Value 0% indicates a full switch-off.	
15	Registartion Time	1...6h	2h		Registration time of combustion history. (At 1 hour -temperature registration every 40s. At 2hrs every 2*40s and so on)	